

ADJUSTABLE CAMS



> MATERIAL:

Steel, Zinc Plated

PHONE: 516.328.3300 • FAX: 516.326.8827 • WWW.SDP-SI.COM

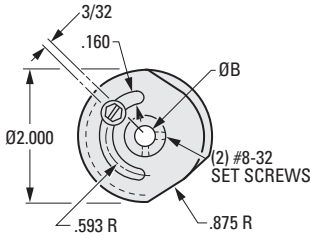
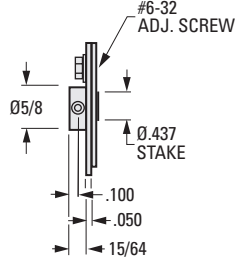

Fig. 1



Adjustment 180°-350°

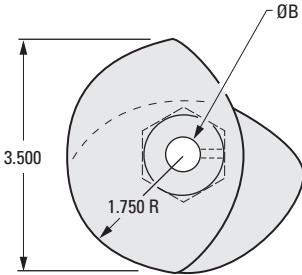
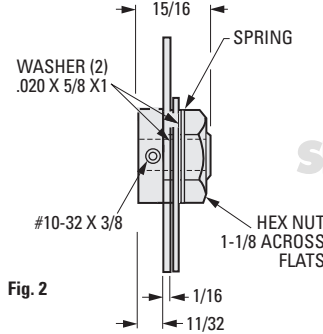

Fig. 2



INCH COMPONENT

Catalog Number	Fig. No.	B Bore +.001 -.000
A 3Y 1-212	1	.3750
A 3Y 1-316	2	.5010

- I
- R
- T
- 1
- 2
- 3
- 4
- 5
- 6
- 7
- 8
- 9
- 10
- 11
- 12
- 13
- 14
- 15
- 16